

COMPACT IRONERS



COMPACT IRONERS

INDEX

- 1.- Product range - Overview
- 2.- Classification
- 3.- Main features
- 4.- Accessories and Options
- 5.- Technical data
- 6.- Sales arguments and marketing tools

1. PRODUCT RANGE

SPE Series



Allows drying, ironing, length and cross folding of linen on 1 or 2 lanes as well as stacking in a side stacker



SP Series



This model dries and irons flat linen and can achieve up to 2 length folds on 1 or 2 lanes



S Series



The simplest model of the range only dries and irons the laundry without folding



1. PRODUCT RANGE

Range	Type of folding	Roll Ø (mm)	Heating	Working width (mm)	
				2600	3300
SPE	2 length folds 3 cross folds stacker	600	Electric, gas and steam	SPE 600-2600	SPE 600-3300
		800		SPE 800-2600	SPE 800-3300
		1000		SPE 1000-2600	SPE 1000-3300
SP	2 length folds	600	Electric, gas and steam	SPE 600-2600	SPE 600-3300
		800		SPE 800-2600	SPE 800-3300
		1000		SPE 1000-2600	SPE 1000-3300
S	Without folding	600	Electric, gas and steam	SPE 600-2600	SPE 600-3300
		800		SPE 800-2600	SPE 800-3300
		1000		SPE 1000-2600	SPE 1000-3300

2. CLASSIFICATION

Heating :

- **Electric [E]** – roll heated by electric heating elements, higher operating costs
- **Gas [G]** – roll heated by atmospheric burners (LPG, NG)
Models with radiant burners available
- **Steam [S]** – roll heated by steam injectors, the best operating costs, investment in a steam boiler needed if not available

2. CLASSIFICATION

Steam



Electric

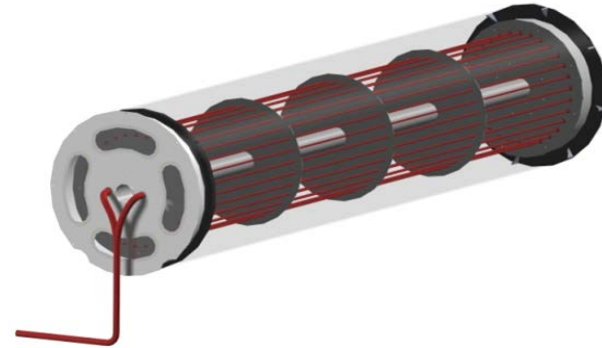

Atmospheric burners (Gas)

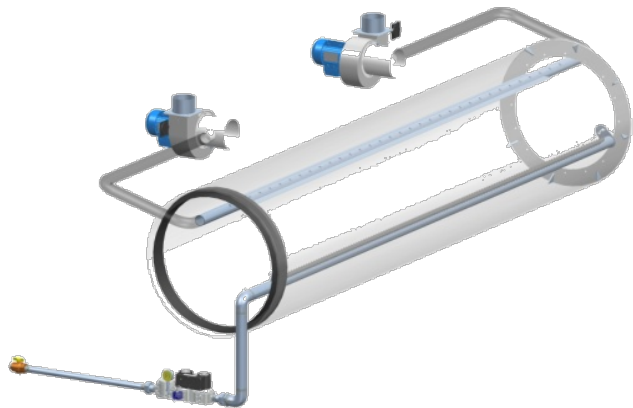

Radiant burners (New - Gas)

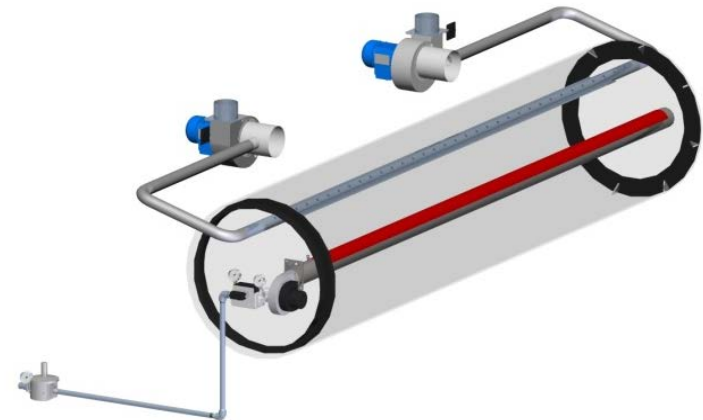

3. MAIN FEATURES

TOUCH CONTROL

- 1 Adjustable
- 2 Easy to use
- 3 High resolution screen



3. MAIN FEATURES

TOUCH CONTROL

- 1 Temperature control
- 2 Program number
- 3 Speed adjustment



3. MAIN FEATURES

TOUCH CONTROL

- 1 PLC test input
- 2 PLC set out
- 3 Language configuration
- 4 Temperature monitor
- 5 Output pieces/hour
- 6 Pieces dimensions control
- 7 Copy of programs
- 8 Backup of programs
- 9 Restore of programs
- 10 Working parameters settings

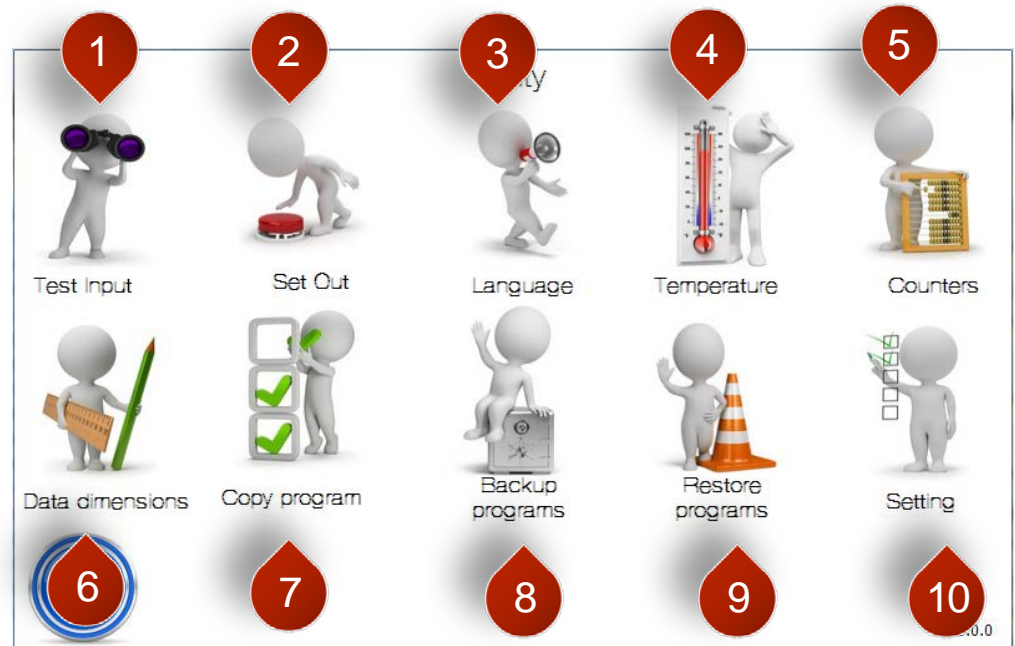

3. MAIN FEATURES

“S” MODEL

- Ironing speed adjustable by manual or automatic mode
- Touch control
- PLC control
- Production information
- Front receipt of linen
- NOMEX ironing belts
- Self cleaning fans
- Automatic roll cool down

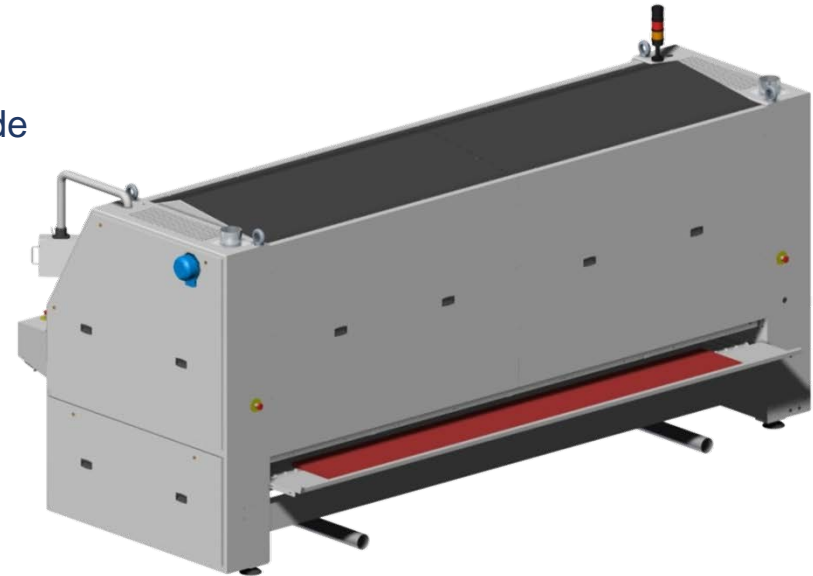

<u>Roll diameter</u>	<u>Working width</u>	<u>heating</u>
600 mm	2600 mm	Gas
800 mm	3300 mm	Steam
1000 mm		Electric

3. MAIN FEATURES

"SP" MODEL

Ironing speed adjustable by manual or automatic mode

Touch control

PLC control

Production information

Software "Time saving" *New*

Front receipt of linen

NOMEX ironing belts

Self cleaning fans

Automatic roll cool down



Roll diameter

600 mm

800 mm

1000 mm

Working width

2600 mm

3300 mm

Heating

Gas

Steam

Electric



3. MAIN FEATURES

“SP” MODEL

Example of ironing and folding, **simple or double length fold**

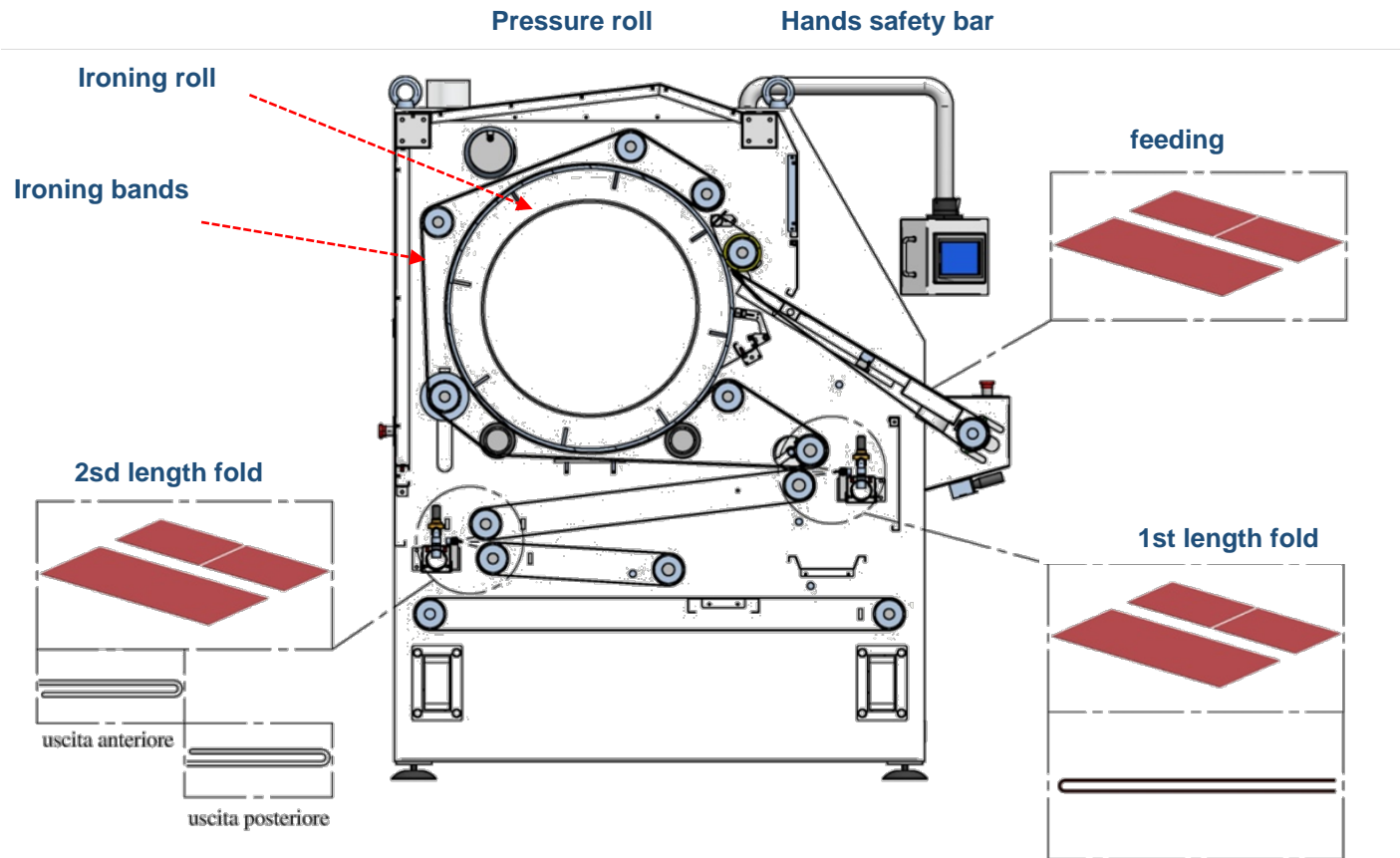

3. MAIN FEATURES

“SPE” MODEL

Ironing speed adjustable by manual or automatic mode

Touch control

PLC control

Production information

Software “Time saving” *New*

Front receipt of linen

NOMEX ironing belts

Self cleaning fans

Automatic roll cool down



<u>Roll diameter</u>	<u>Working width</u>	<u>Heating</u>	<u>Working lanes number</u>	<u>Stacker</u>
600 mm	2600 mm	Gas	1 lane	Side stacker
800 mm	3300 mm	Steam	2 lanes	Compact stacker (Roll-off)
1000 mm		Electric		

3. MAIN FEATURES

“SPE” MODEL
Lanes features

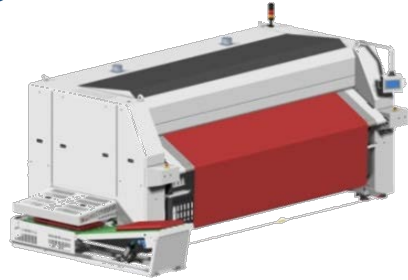

lanes

1

Length folds

2

Cross folds

3

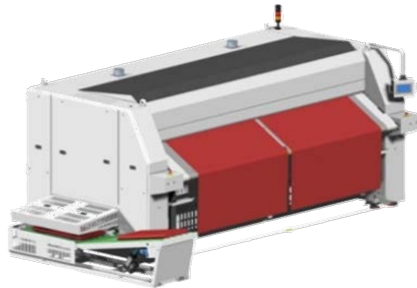

2

2

2

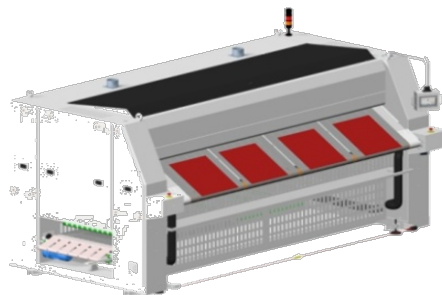

>2

-

-

3. MAIN FEATURES

“SPE” MODEL

Various examples of programs combinations:

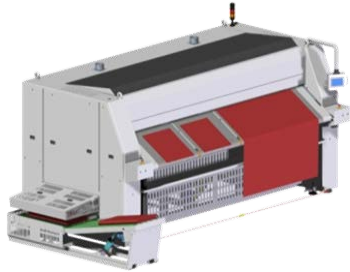

Right lane



Left lane

ironing

Left lane exit

Rear exit



Right lane exit

Side stacker

Left lane exit

Rear exit
+
small pieces receipt 2 lanes

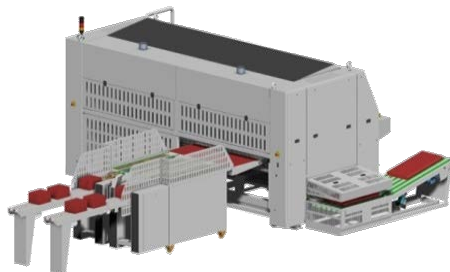

Right lane exit

Side stacker

Left lane exit

Rear exit
+
Small pieces folding

3. MAIN FEATURES

“SPE” MODEL

Example of ironing with **simple or double length folding**

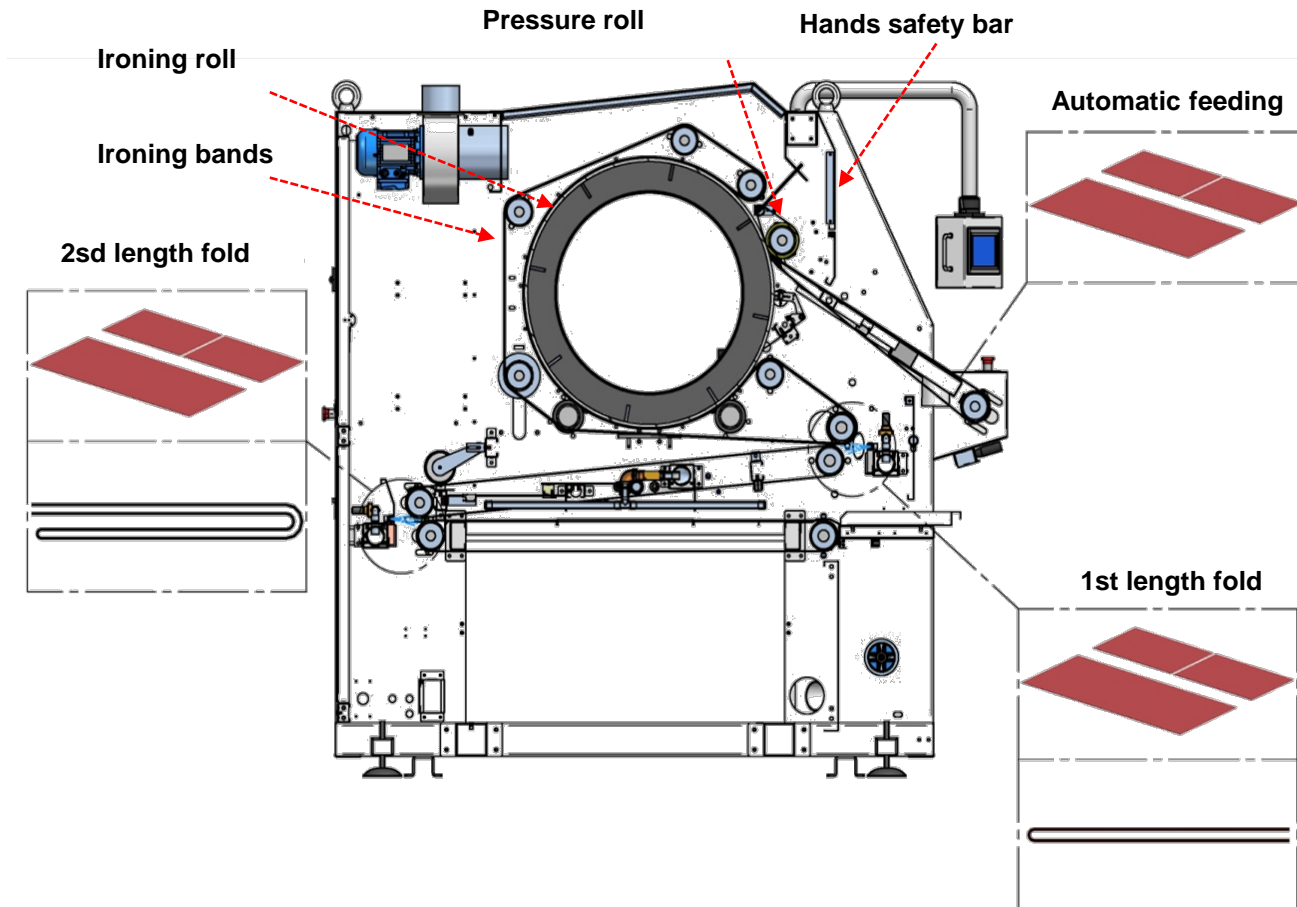

3. MAIN FEATURES

“SPE” MODEL

Example with 3 CROSS FOLDS on 1 lane: central lane

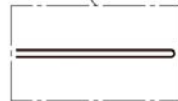
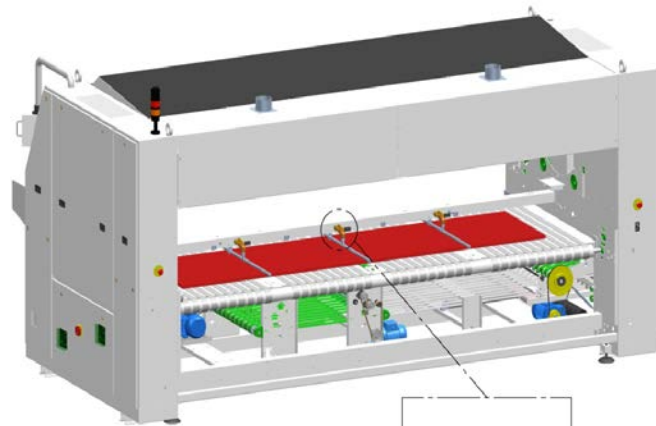

1st cross fold

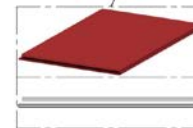
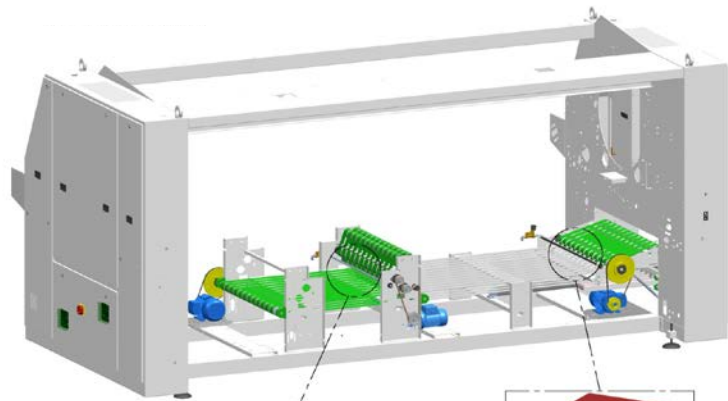

2sd cross fold

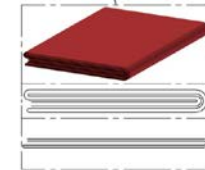

3rd fold
By-pass
3rd fold

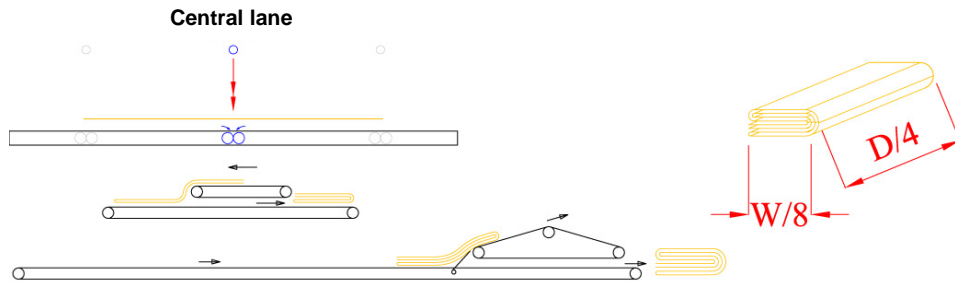

3. MAIN FEATURES

“SPE” MODEL

Example with **2 CROSS FOLDS** on 2 lanes

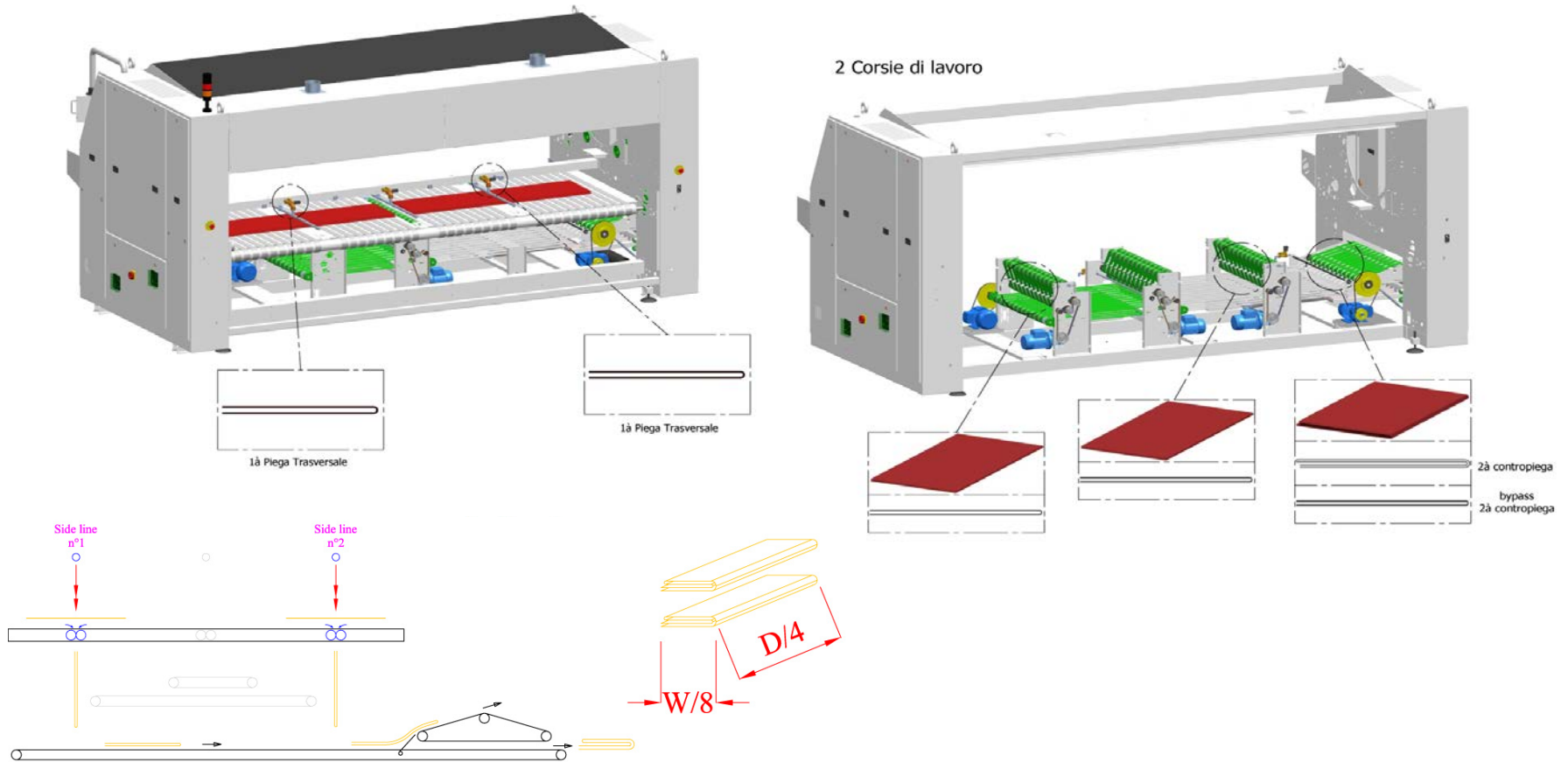

4. ACCESSORIES AND OPTIONS

S & SP

- 1 Vacuum table
- 2 Automatic feeder
- 3 Small pieces receipt 2 or 4 lanes

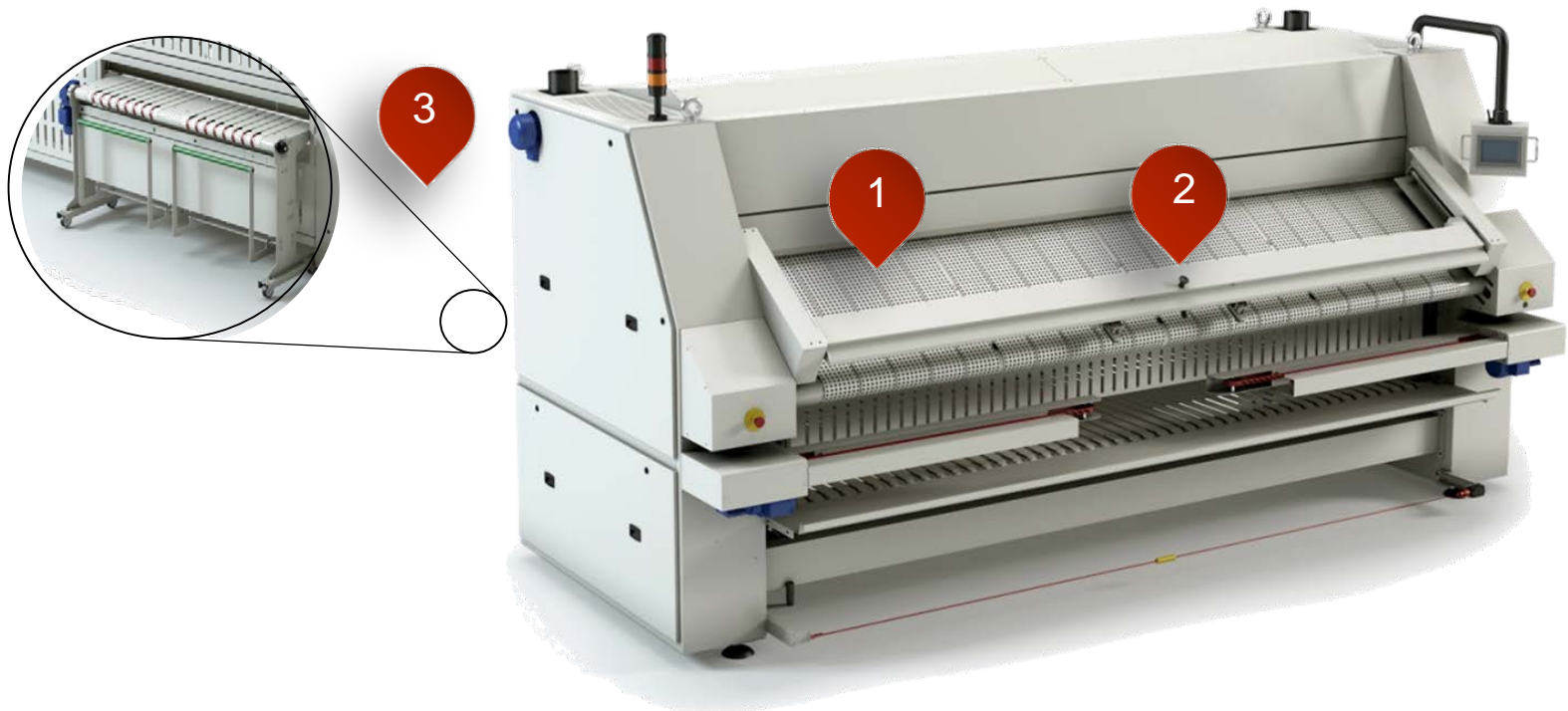

4. ACCESSORIES AND OPTIONS

S & SP

- 1 Rear exit
- 2 By-pass (only for SP)
- 3 Reject button for dirty or torn linen

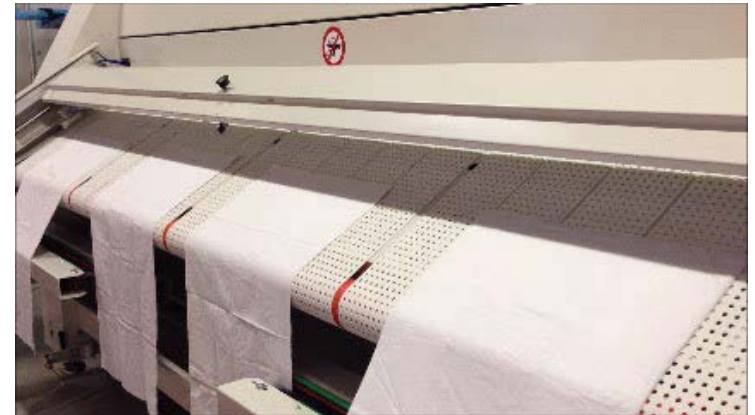
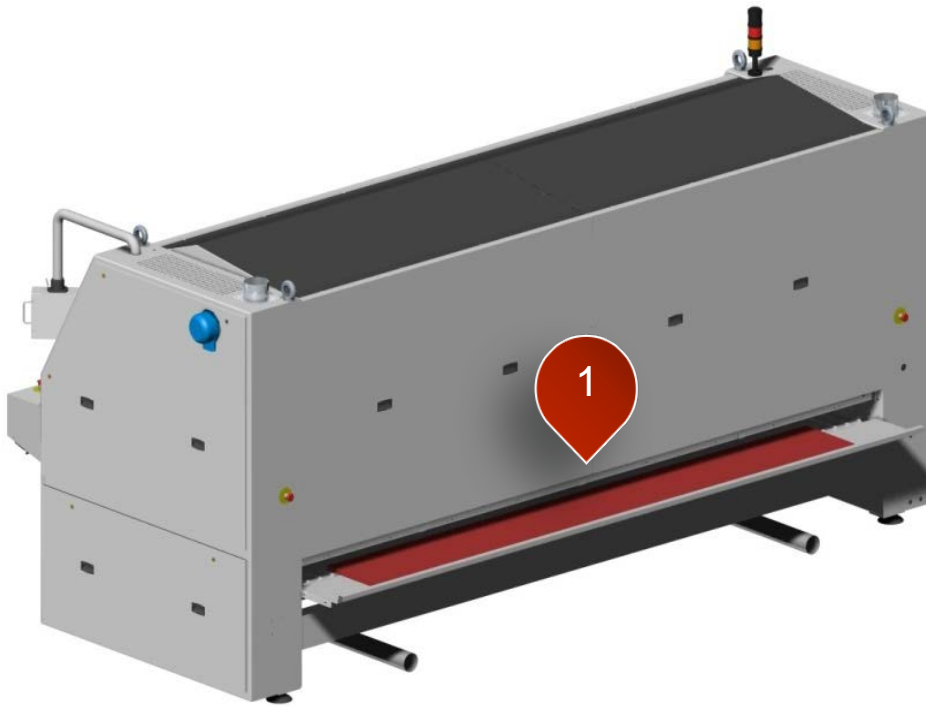

4. ACCESSORIES AND OPTIONS

SPE

- 1 Vacuum table
- 2 Automatic feeder
- 3 Compact side stacker "roll off"



4. ACCESSORIES AND OPTIONS

SPE

- 1 Small pieces receipt on 2 or 4 lanes
- 2 Side stacker

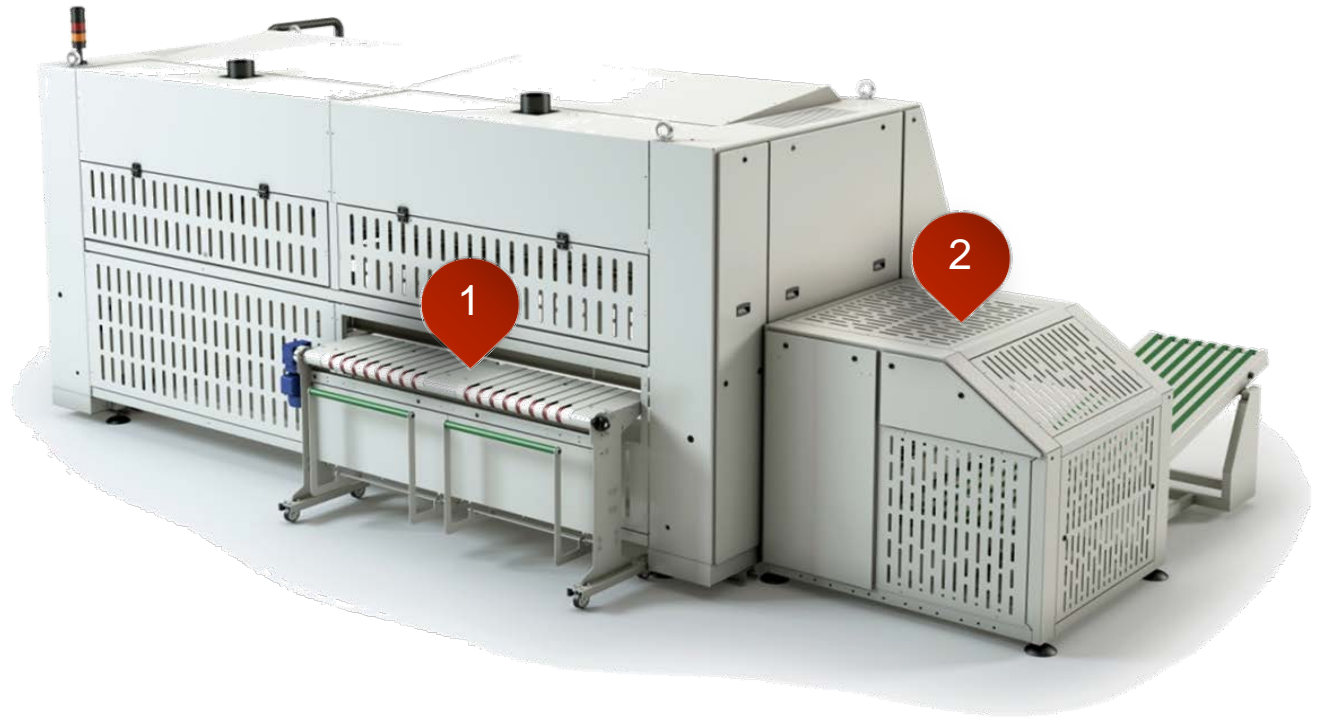

4. ACCESSORIES AND OPTIONS

SPE

- 1 By-Pass
- 2 Reject button for dirty or torn linen



4. ACCESSORIES AND OPTIONS

S & SP & SPE

Pallet packing



Standard packing



4. ACCESSORIES AND OPTIONS

S & SP & SPE

Seaworthy packing



Standard packing



